

PRODUCT INFORMATION AND SPECIFICATIONS

PRECISION DISPENSING CORES

PRECISION DISPENSING CORES

These Patented Precision Dispensing Cores offer further cost savings over complete nozzle replacement.

Use of these cores in combination with our Re-usable hub will eliminate full component replacement costs and time consuming cleaning processes.

The unique slotted taper allows easy installation and removal of dispense cores.



FEATURES

- Added cost savings
- Quick replacement
- Ideal for high volume manufacturing
- Reduce or eliminate cleaning time
- Available in all size offerings



Figure 1

CORE SPECIFICATIONS

NICKEL SILVER

- UNS C73500
COPPER, CU 72%
NICKEL, NI 18%
ZINC, ZN 10%

PHOSPHOR BRONZE

- UNS C5100
COPPER, CU 95%
TIN, TN 05%

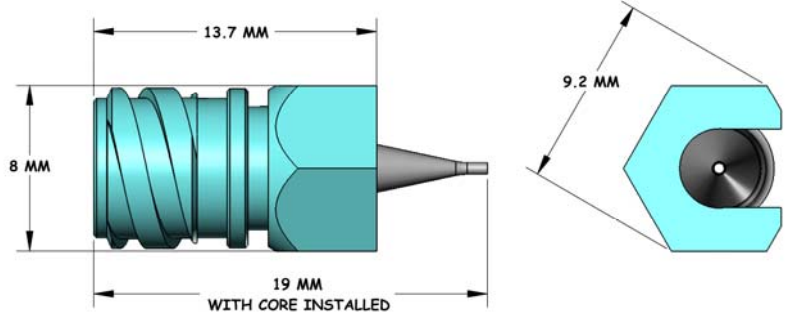

HOW TO ORDER

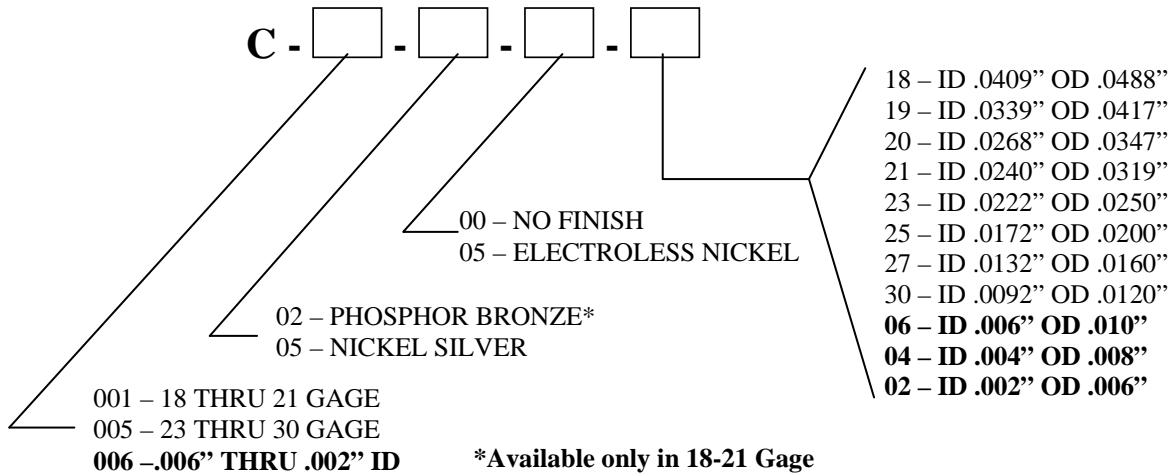

Subrex reserves the right to make design/material changes to products to improve their functionality. These changes may occur between publishing.

©2010 Subrex Published 25 April 10

US Patent No. 7,231,716; others pending



MADE IN THE USA

Email: info@subrex.com
URL: www.subrex.com

Subrex

7407 Brava Street
Carlsbad, CA 92009 USA
Tel: 760.436.1521